

# High Efficiency Local Blowers

The Proline Local Blowers are designed specifically for our ProV series of hoods, providing exceptional ventilation. With powerful airflow options of 1200 CFM or 1700 CFM, these blowers ensure your kitchen remains free of smoke, odors, and excess heat. Perfectly engineered for seamless integration, they deliver optimal performance for any cooking environment.

These local blowers feature 10" outlets for efficient venting and operate on 110V with a single motor, providing reliable and consistent performance. The variable speeds can be easily adjusted using a rheostat knob, allowing you to control the ventilation according to your needs. Constructed from durable steel, these blowers are built to withstand the demands of a busy kitchen.

The Proline Local Blowers come with a 10-year warranty, ensuring long-term reliability and peace of mind. They are ETL certified, meeting the highest safety and quality standards. The blowers include all necessary hardware for installation within the inner shell of your range hood, ensuring superior ventilation performance that keeps your kitchen clean and comfortable, no matter what you're cooking.

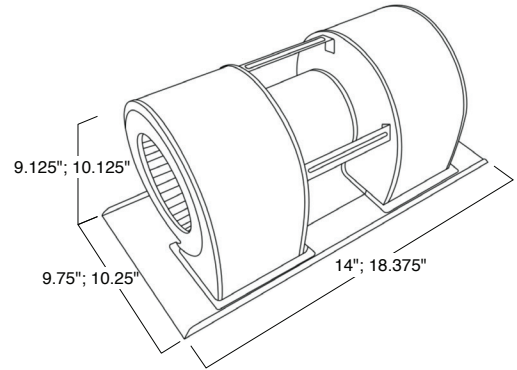

**Product Specifications**

<b>1200 CFM</b> . . . . .	14" W x 9.75" D x 9.125" H
<b>1700 CFM</b> . . . . .	18.375" W x 10.25" D x 10.125" H
Venting Size. . . . .	10" Outlets
Airflow. . . . .	1200 or 1700 CFM
Voltage . . . . .	110V
Motor . . . . .	Single
Speeds . . . . .	Variable
Control Type . . . . .	Rheostat Knob
Material . . . . .	High-Quality Steel
Warranty . . . . .	10 Year Warranty
Certifications . . . . .	ETL Certified