



## Inline Blower – 1300 CFM

The Proline Inline 1300 CFM Blower is a powerful and efficient solution for enhancing your kitchen ventilation. Designed to seamlessly integrate with our ProV series of hoods, this blower ensures optimal airflow and performance. Installed in your ducting, this inline blower performs quietly while also delivering impressive ventilation, making it the ideal choice for any modern kitchen setup.

This inline blower features 10" outlets for efficient venting, delivering an impressive airflow of 1300 CFM. Operating on 110V, the single motor provides reliable performance with variable speeds controlled by a convenient rheostat knob. Constructed from durable steel with sturdy mounting brackets, this blower is built to last.

The Proline Inline 1300 CFM Blower comes with a 10-year warranty, ensuring long-term peace of mind. It is also ETL certified, meeting high safety and quality standards. Whether you're cooking a quick meal or hosting a large gathering, this blower efficiently manages kitchen fumes and odors, providing a clean and comfortable cooking environment.

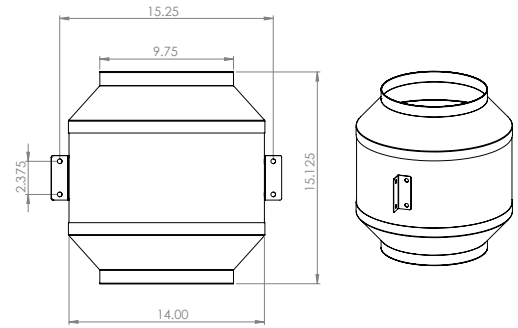

### Product Specifications

Sizes Available . . . . .	14" W x 15.125" H
Venting Size. . . . .	10" Outlets
Airflow. . . . .	1300 CFM
Voltage . . . . .	110V
Motor . . . . .	Single
Speeds . . . . .	Variable
Control Type . . . . .	Rheostat Knob
Material . . . . .	Steel with Mounting Brackets
Warranty . . . . .	10 Year Warranty
Certifications. . . . .	ETL Certified