



## PLSW 750G

The PLSW 750G Wall Mounted Range Hood combines modern design with high functionality, making it a perfect addition to any contemporary kitchen. Available in 30" and 36" sizes, this sleek range hood features a stylish black glass accent panel that adds a touch of elegance to its design.

Equipped with advanced digital touch controls, the PLSW 750G offers intuitive operation and ease of use. The range hood features 1.5W LED lighting to brightly illuminate your cooking area, providing both functionality and energy efficiency. With a powerful ventilation system that boasts a maximum airflow capacity of 550 CFM, this range hood effectively removes smoke, grease, and odors from your kitchen environment.

The single motor ensures efficient performance, while the stainless steel baffle filters are dishwasher safe, making maintenance a breeze. Crafted from high-quality 430 stainless steel and highlighted by a sleek black glass panel, this range hood is built for durability and modern aesthetics. Backed by a 3-year parts warranty, the PLSW 750G Wall Mounted Range Hood is a reliable and stylish choice for enhancing your kitchen's ventilation.

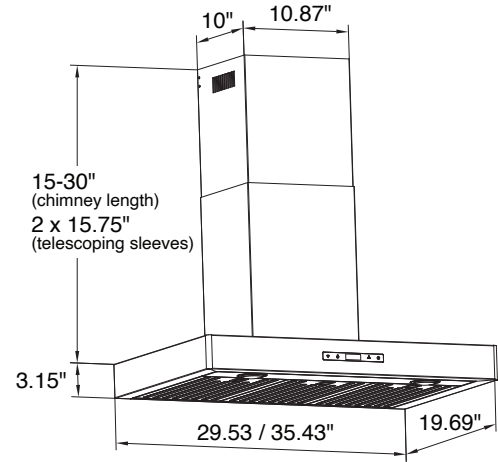

### Configuration and Dimensions

Hood Type . . . . .	Wall Mounted
Sizes Available . . . . .	30   36
30" Dimensions . . . . .	29.53" W x 16.69" D x 3.15" H
36" Dimensions . . . . .	35.43" W x 16.69" D x 3.15" H

### Features

Control Type . . . . .	Digital Touch Control
Lighting . . . . .	1.5W LED

### Ventilation System

Maximum Air Flow Capacity . . . . .	550 CFM
Speed Levels . . . . .	3 Speed
Airflow (Quiet/Low/Med/High) . . . . .	.150/350/550
Noise Level . . . . .	.65 db or 13 Sones Max
Duct Type/Size . . . . .	6" Round
Voltage . . . . .	110v
Motor . . . . .	.Single
Filter Type . . . . .	Stainless Steel Baffle (Dishwasher Safe)
Material . . . . .	High Quality 430 Stainless Steel
Warranty . . . . .	.3 Year Parts Warranty