

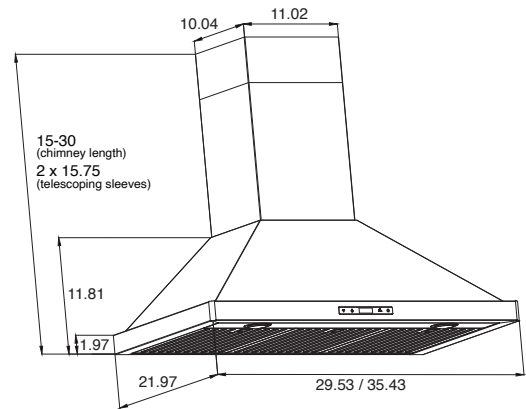

PLSW 520RC

The PLSW 520 Wall Mounted Range Hood is a testament to innovation and superior design in kitchen ventilation, showcasing a blend of advanced technology and high performance. With a powerful 550 CFM motor, it stands out for its efficiency in removing kitchen pollutants, ensuring a clean and healthy cooking environment. This model is designed for eco-friendly operation, emphasizing maximum airflow with minimal energy consumption. Operating quietly at 65 dB, it offers a perfect mix of power and tranquility, thanks to its design and superior components that reduce vibration and noise. The inclusion of two 1.5W LED lights provides bright, energy-efficient illumination, while the digital touch control panel allows for easy adjustment across three speeds, ensuring optimal ventilation. The PLSW 520, with its 6" round outlet for effective air expulsion, represents the pinnacle of modern kitchen ventilation, combining sleek design with outstanding functionality.



Configuration and Dimensions

Hood Type	Wall Mounted
Sizes Available	30 36
30" Dimensions	29.53" W x 21.97" D x 9.84" H
36" Dimensions	35.43" W x 21.97" D x 9.84" H

Features

Control Type	Digital Touch Control
Lighting	1.5W LED

Ventilation System

Maximum Air Flow Capacity	550 CFM
Speed Levels	3 Speed
Airflow (Quiet/Low/Med/High)	150/350/550
Noise Level65 db or 13 Sones Max
Duct Type/Size	6" Round
Voltage	110v
Motor	Dual
Filter Type	Stainless Steel Baffle (Dishwasher Safe)
Material	High Quality 430 Stainless Steel
Warranty	3 Year Parts Warranty