



PLSI 575G

The PLSI 575G Island Mounted Range Hood seamlessly blends contemporary design with high functionality, creating a striking focal point for any modern kitchen. This new round hood features an elegant glass disc detail, crafted from 8 mm-thick tempered glass, adding a touch of sophistication to its sleek, low-profile design.

Equipped with advanced digital touch controls, the PLSI 575G offers intuitive operation and ease of use. The 1.5W LED lighting provides bright, energy-efficient illumination for your cooking area. With a powerful ventilation system boasting a maximum airflow capacity of 550 CFM, this hood effectively removes smoke, grease, and odors from your kitchen environment. It features three speed levels, allowing you to adjust the airflow to suit your cooking needs.

The stainless steel baffle filters are dishwasher safe, making maintenance simple. Crafted from high-quality 430 stainless steel and highlighted by its distinctive glass disc detail, this range hood combines durability with modern aesthetics. Backed by a 3-year parts warranty, the PLSI 575G Island Mounted Range Hood is a reliable and stylish choice for enhancing your kitchen's ventilation.

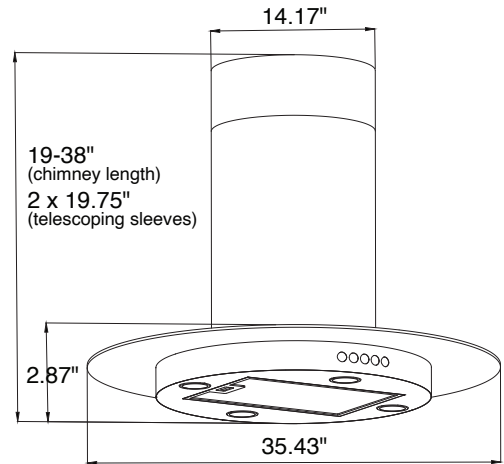

Configuration and Dimensions

Hood Type	Island Mounted
Sizes Available	36
36" Dimensions	35.43" W x 2.87" H

Features

Control Type	Digital Touch Control
Lighting	1.5W LED

Ventilation System

Maximum Air Flow Capacity	550 CFM
Speed Levels	3 Speed
Airflow (Quiet/Low/Med/High)	150/350/550
Noise Level65 db or 13 Sones Max
Duct Type/Size	6" Round
Voltage	110v
Motor	Single
Filter Type	Stainless Steel Baffle (Dishwasher Safe)
Material	High Quality 430 Stainless Steel
Warranty3 Year Parts Warranty