

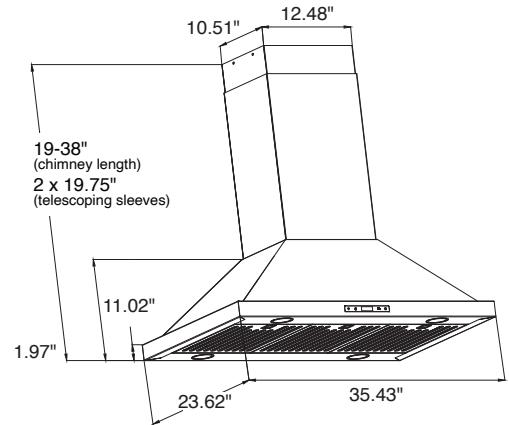

## PLSI 520

The PLSI 520.36 Island Mounted Range Hood is a standout in modern kitchen design, offering both functionality and style for kitchen islands. With dimensions of 35.43 inches in width and 23.62 inches in depth, this 36-inch model enhances contemporary kitchens as a sophisticated centerpiece. Its minimalist design, featuring sleek lines, complements modern decors, elevating the kitchen's aesthetic. Powered by a 550 CFM motor, it efficiently removes smoke and odors, ensuring a clean, comfortable environment with eco-friendly energy use. Operating at a quiet 65 dB, it combines powerful performance with minimal noise. The hood is equipped with four 1.5W LED lights for bright, efficient lighting, and a digital touch control panel for easy speed adjustments (150/350/550), alongside a 6" round outlet for effective ventilation, making the PLSI 520.36 a symbol of modern kitchen elegance and efficiency.



### Configuration and Dimensions

Hood Type . . . . .	Island Mounted
Sizes Available . . . . .	36
36" Dimensions . . . . .	35.43" W x 23.62" D x 11.02" H

### Features

Control Type . . . . .	Digital Touch Control
Lighting . . . . .	1.5W LED

### Ventilation System

Maximum Air Flow Capacity . . . . .	550 CFM
Speed Levels . . . . .	3 Speed
Airflow (Quiet/Low/Med/High) . . . . .	150/350/550
Noise Level . . . . .	.65 db or 13 Sones Max
Duct Type/Size . . . . .	6" Round
Voltage . . . . .	110v
Motor . . . . .	.Dual
Filter Type . . . . .	Stainless Steel Baffle (Dishwasher Safe)
Material . . . . .	High Quality 430 Stainless Steel
Warranty . . . . .	.3 Year Parts Warranty