



PLGI 104

The PLGI 104 Island Range Hood combines style and functionality, designed as the centerpiece of any modern kitchen. Available in four sizes—36", 42", 48", and 60"—this island mount hood features a sleek design to complement any kitchen decor. The precise dimensions ensure a perfect fit for various kitchen layouts, providing both aesthetic appeal and practical ventilation.

With a powerful ventilation system, the PLGI 104 offers a maximum air flow of 1600 CFM, efficiently removing smoke, grease, and odors. Four speed levels and a noise level of just 56.06 dB ensure quiet yet powerful performance. Dual motors and stainless steel baffle filters, which are dishwasher safe, guarantee long-lasting durability and easy maintenance.

Designed for convenience, the PLGI 104 features rotary switch controls and bright LED lighting with 8 bulbs to illuminate your cooking space. Constructed from high-quality 304 stainless steel, this range hood is built to last and comes with a 3-year parts warranty, offering reliable performance for years. Whether you are a home chef or an avid entertainer, the PLGI 104 Island Range Hood delivers efficiency and elegance.

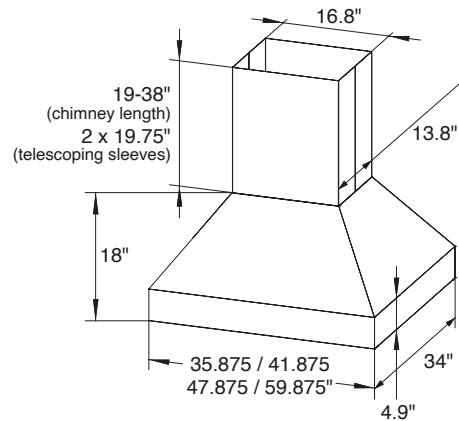

Configuration and Dimensions

Hood Type	Island Mount
Sizes Available	36 42 48 60
36" Dimensions	36" W x 33.8" D x 37.4" H
42" Dimensions	42" W x 33.8" D x 37.4" H
48" Dimensions	48" W x 33.8" D x 37.4" H
60" Dimensions	60" W x 33.8" D x 37.4" H
Chimney Dimensions	16.8" W x 13.8" D x 19-38" H

Features

Control Type	Rotary Switch
Lighting	8 x LED

Ventilation System

Maximum Air Flow Capacity	1600 CFM
Speed Levels	4
Noise Level	56.06 db or 7 Sones Max
Duct Type/Size	2 x 8
Voltage	110v
MotorDual
Filter Type	Stainless Steel Baffle (Dishwasher Safe)
Material	High Quality 304 Stainless Steel
Warranty3 Year Parts Warranty