

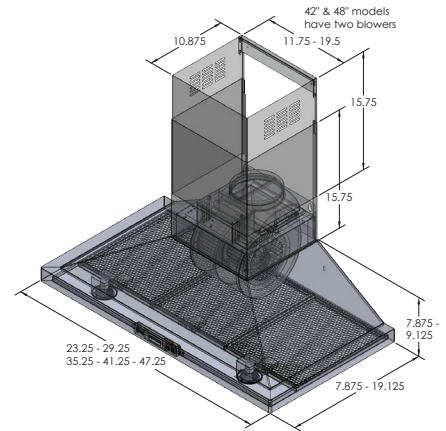

**PLFW 520** the PLFW 520 includes high-efficiency stainless steel mesh filters that filter grease, dirt, and unwanted air out of your kitchen. This wall hood will drastically improve your indoor air quality and contribute to a healthy, comfortable lifestyle. With a dual 600 CFM blower, the 520 has enough power for any job in the kitchen. If you don't need all that power, you can adjust it with the push of a button. The LED display control panel with push buttons features blower speed controls – this model has six different speeds! Also on the control panel, you'll find LED lights controls. These are really convenient to brighten your entire cooktop while cooking! And finally, when you're finishing up in the kitchen, after 1-2 months of use, toss your stainless steel mesh filters into your dishwasher. Easy! The 520 provides impressive functionality and looks beautiful in the kitchen.



**Configuration and Dimensions**

Wall Type . . . . .	Wall
Sizes Available . . . . .	24   30   36   42   48
24" Dimensions . . . . .	23.25" W x 19.125" D x 7.875" H
30" Dimensions . . . . .	29.25" W x 19.125" D x 7.875" H
36" Dimensions . . . . .	35.25" W x 19.125" D x 7.875" H
42" Dimensions . . . . .	41.25" W x 19.125" D x 7.875" H
48" Dimensions . . . . .	47.25" W x 19.125" D x 7.875" H

**Features**

Control Type . . . . .	Featherweight Touch Buttons with LED Display
Lighting . . . . .	LED

**Ventilation System**

Maximum Air Flow Capacity . . . . .	600 or 1100 CFM
Speed Levels . . . . .	6 Speeds
Airflow (Quiet/Low/Med/High) . . . . .	100/200/300/400/500/600
Noise Level . . . . .	48 db or 4 Sones Max
Duct Type/Size . . . . .	Round 6
Voltage . . . . .	110v
Motor . . . . .	Single or Dual
Filter Type . . . . .	Stainless Steel Mesh (Dishwasher Safe)
Material . . . . .	High Quality 430 Stainless Steel
Warranty . . . . .	.3 Year Parts Warranty